

Salinity-gradient power: Evaluation of pressure-retarded osmosis and reverse electrodialysis

Jan W. Post^{a,b}, Joost Veerman^b, Hubertus V.M. Hamelers^{a,*}, Gerrit J.W. Euverink^b,
Sybrand J. Metz^b, Kitty Nymeijer^c, Cees J.N. Buisman^{a,b}

^a Wageningen University, Sub-Department of Environmental Technology, P.O. Box 8129, 6700 EV Wageningen, The Netherlands

^b Wetsus, Centre for Sustainable Water Technology, P.O. Box 1113, 8900 CC Leeuwarden, The Netherlands

^c University of Twente, Faculty of Science and Technology, Membrane Technology Group, P.O. Box 217, 7500 AE Enschede, The Netherlands

Received 11 April 2006; received in revised form 14 November 2006; accepted 17 November 2006

Available online 23 November 2006

Abstract

A huge potential to obtain clean energy exists from mixing water streams with different salt concentrations. Two membrane-based energy conversion techniques are evaluated: pressure-retarded osmosis and reverse electrodialysis. From the literature, a comparison is not possible since the reported performances are not comparable. A method was developed which allows for a comparison of both techniques at equal conditions, with respect to power density and energy recovery. Based on the results from the model calculations, each technique has its own field of application. Pressure-retarded osmosis seems to be more attractive for power generation using concentrated saline brines because of the higher power density combined with higher energy recovery. Reverse electrodialysis seems to be more attractive for power generation using seawater and river water. These conclusions are valid for present and latent performances of both techniques. According to the model, the potential performances of both techniques are much better than the current performances. In order to achieve these potential performances, the development of pressure-retarded osmosis must focus on membrane characteristics, i.e. increasing the water permeability of the membrane skin and optimization of the porous support. The development of reverse electrodialysis, however, must focus on system characteristics, i.e. optimization of the internal resistance, which is mainly determined by the width of the spacers.

© 2006 Elsevier B.V. All rights reserved.

Keywords: Salinity-gradient energy; Pressure-retarded osmosis; Reverse electrodialysis; Blue energy; Renewable energy

1. Introduction

The need for clean and sustainable energy sources is quite evident, since fossil fuels have a number of drawbacks: such as emissions of greenhouse gases, depletion of finite sources, and dependence on a few oil-exporting regions in the world. Current energy conversion techniques that are considered to be sustainable include solar, wind, biomass, and hydro energy. There are other sources of sustainable energy including, but not limited to tidal power, ocean wave power, ocean thermal energy conversion which are discussed by Wick and Schmitt [1]. A significant potential to obtain clean energy exists from mixing water streams

with different salt concentrations. This salinity-gradient energy, in the research programs of our institutes also called blue energy, is available worldwide where fresh water streams flow into the sea. The global energy output from estuaries is estimated at 2.6 TW [1], which represents approximately 20% of the present worldwide energy demand. Large amounts of blue energy can also be made available from natural or industrial salt brines.

In general, techniques currently available for desalination could be used to generate power from salinity gradients when operated in the reversed mode [2]. In the literature, several techniques for energy conversion of the salinity gradient have been proposed: pressure-retarded osmosis [3], reverse electrodialysis [4], and vapor-pressure difference utilization [5]. Although the potential for salinity-gradient energy was recognized more than half a century ago [4], until now utilization has been considered to be neither economically feasible nor technically attractive when compared to fossil fuel systems.

* Corresponding author. Tel.: +31 317 483447; fax: +31 317 482108.

E-mail addresses: Bert.Hamelers@wur.nl (H.V.M. Hamelers),
d.c.nijmeijer@utwente.nl (K. Nymeijer).

The main drawback of these membrane-based conversion techniques was the high price of membranes. However, the decreasing prices of membranes for desalination and water reuse applications as well as the increasing prices of fossil fuels make salinity-gradient power attractive in near future. Therefore, reconsideration of the available membrane-based processes for the production of sustainable power from salinity-gradient energy is worthwhile.

Pressure-retarded osmosis and reverse electrodialysis are the most frequently studied membrane-based processes for energy conversion of salinity-gradient energy. To the best of our knowledge, there is no study which compares both techniques. Such an evaluation is a prerequisite to highlight the potential and challenges for further development of both techniques. Our objective is to evaluate and compare the potential of pressure-retarded osmosis and reverse electrodialysis.

2. Theory

2.1. Principles

2.1.1. Principle of pressure-retarded osmosis

In a pressure-retarded osmosis system, two solutions of different salinity are brought into contact by a semi-permeable membrane (Fig. 1). This membrane allows the solvent (i.e. water) to permeate and retains the solute (i.e. dissolved salts). The chemical potential difference between the solutions causes transport of water from the diluted salt solution to the more concentrated salt solution. If hydrostatic pressure is applied to the concentrated solution, the water transport will be partly retarded. The transport of water from the low-pressure diluted solution to the high-pressure concentrated solution results in a pressurization of the volume of transported water. This pressurized volume

of transported water can be used to generate electrical power in a turbine.

2.1.2. Principle of reverse electrodialysis

In a reverse electrodialysis system, a number of cation and anion exchange membranes are stacked in an alternating pattern between a cathode and an anode (Fig. 2). The compartments between the membranes are alternately filled with a concentrated salt solution and a diluted salt solution. The salinity gradient results in a potential difference (e.g. 80 mV for seawater and river water) over each membrane, the so-called membrane potential. The electric potential difference between the outer compartments of the membrane stack is the sum of the potential differences over each membrane.

The chemical potential difference causes the transport of ions through the membranes from the concentrated solution to the diluted solution. For a sodium chloride solution, sodium ions permeate through the cation exchange membrane in the direction of the cathode, and chloride ions permeate through the anion exchange membrane in the direction of the anode. Electro-neutrality of the solution in the anode compartment is maintained via oxidation at the anode surface. Electro-neutrality of the solution in the cathode compartment is maintained via reduction at the cathode surface. As a result, an electron can be transferred from the anode to the cathode via an external electric circuit. This electrical current and the potential difference over the electrodes can be used to generate electrical power, when an external load or energy consumer is connected to the circuit.

2.2. Comparison of techniques based on data from the literature

An evaluation and comparison of pressure-retarded osmosis and reverse electrodialysis is made by reviewing the lit-

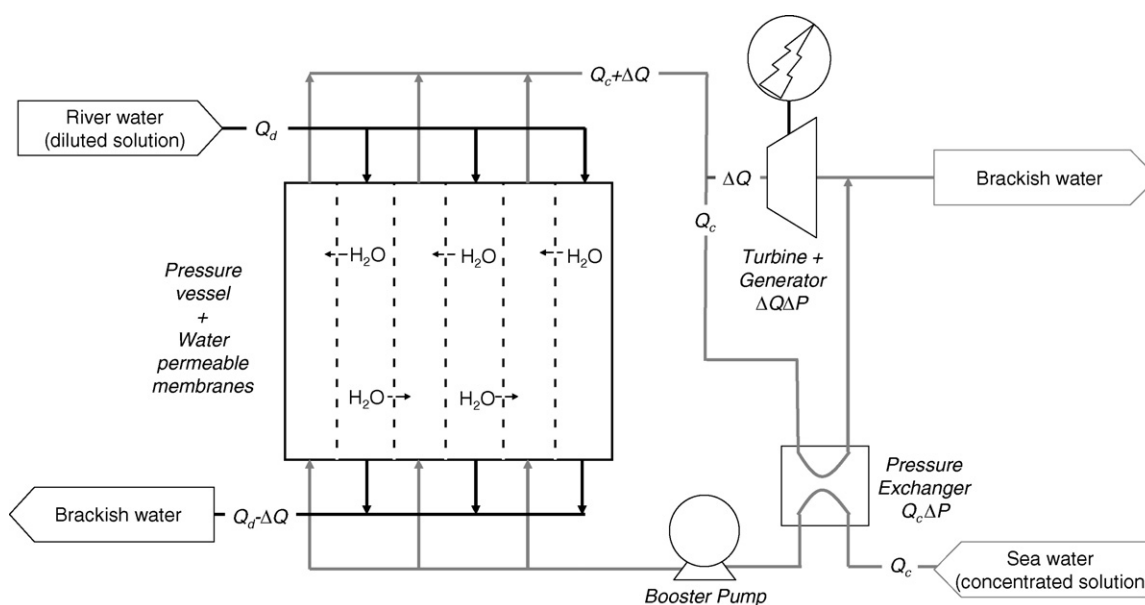

Fig. 1. Conceptual representation of an energy conversion scheme using pressure-retarded osmosis; Q is the volumetric solution flow (m^3/s), ΔQ the transported amount of water in time through the membranes (m^3/s), ΔP the applied hydrostatic pressure difference between both solutions (Pa), whereas the power generated by means of a turbine and generator is $\Delta Q \Delta P$ (W).

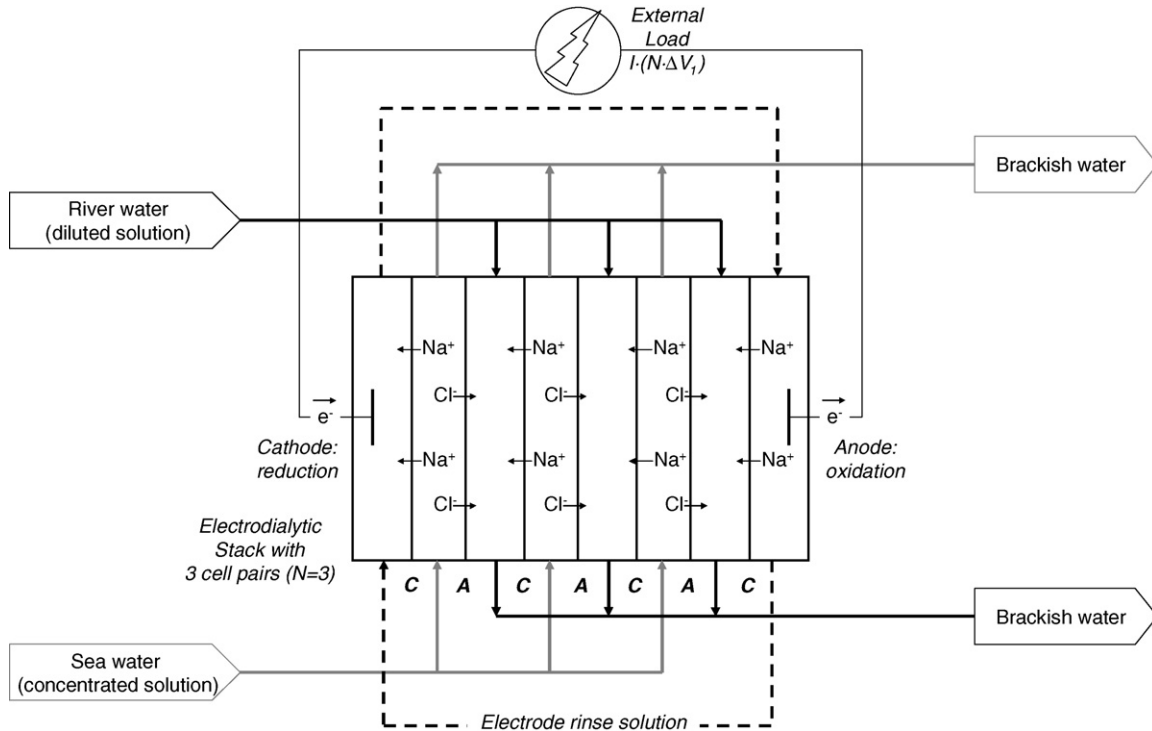

Fig. 2. Conceptual representation of an energy conversion scheme using reverse electrodialysis; A is an anion exchange membrane, C a cation exchange membrane, I the electrical current or transported charge (A), N the number of cell pairs (in this case $N=3$), $N \Delta V_1$ the potential difference over the applied external load (V), whereas the power generated is $I(N\Delta V)$ (W).

erature. The literature that reported experimental data was culled.

2.2.1. Experimental data for pressure-retarded osmosis

Pressure-retarded osmosis is the most studied membrane-based technique for energy production from salinity gradients. The amount of experimental data, however, is limited and difficult to compare with each other. In general, the obtained power is not reported separately, but can be derived from the available data (e.g. water flux, applied hydrostatic pressure). Obtained power densities are presented in Fig. 3.

Currently available reverse osmosis membranes in a pressure-retarded osmosis application on seawater and fresh water (osmotic pressure difference $\Delta\pi=20$ –25 bar) could yield a power density between 0.11 and 1.22 W/m² (Fig. 3). The higher value is obtained for mixing two solutions with $\Delta\pi=39$ bar using cellulose acetate membranes [6]. According to Lee [7], cellulose acetate membranes should have favorable characteristics for pressure-retarded osmosis: high permeability, high salt rejection and low transport resistance of the support layer. A power density of 1.54 W/m² was predicted [7].

Currently available reverse osmosis membranes in a pressure-retarded osmosis application on more concentrated brines and fresh water ($\Delta\pi>75$ bar) could yield a power density of 2–5 W/m² (Fig. 3). Hollow-fiber aromatic polyamide membranes provide the most promising power densities [8]. Later experiments with spiral-wound cellulose acetate membranes were limited by the applied hydrostatic pressure difference ($\Delta P<24$ bar) [6]. For this reason, it is not possible to draw con-

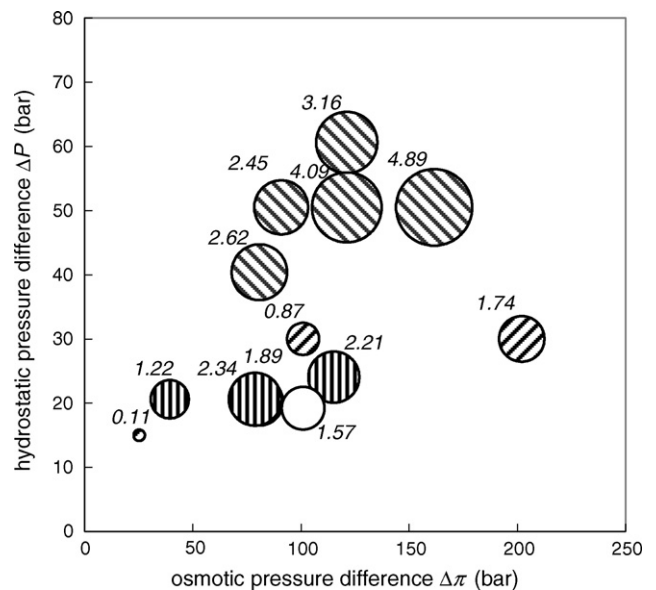

Fig. 3. Power densities (W/m²) obtained with pressure-retarded osmosis; $\Delta\pi$ is the osmotic pressure difference between the two salt solutions and ΔP the applied hydrostatic pressure difference over the membrane. Diameter of the bullets represents the power density as derived from reported osmotic pressure, hydrostatic pressure, and from water fluxes (▨: Loeb et al. [20]) or from permeation coefficients (▩: Mehta and Loeb [8]; □: Loeb and Mehta [26]; ▨: Mehta [6]). Applied membrane materials: polyamide [8,20], cellulose acetate [6], furan skin [26].

clusions on which membrane material (e.g. aromatic polyamide or cellulose acetate) or which configuration (e.g. hollow-fiber or flat-sheet) is favorable for application on more concentrated brines.

2.2.2. Experimental data for reverse electro dialysis

For reverse electro dialysis, the published experimental data is scarcer than for pressure-retarded osmosis. Obtained power densities are presented in Fig. 4.

Currently available electro dialysis membranes in a reverse electro dialysis application on seawater and fresh water (electrochemical potential difference $\Delta\phi=0.17\text{ V}$) could yield a power density of 0.41 W/m^2 (Fig. 4). This power density was obtained with heterogeneous modified polyethylene membranes and shaped, chemically modified spacers. According to Jagur-Grodzinski et al. [9], the spacer characteristics, i.e. the control of flow patterns, seemed to be more important than the membrane characteristics, since all tested membranes were comparable with respect to perm selectivity and resistance.

Currently available electro dialysis membranes in a reverse electro dialysis application on more concentrated brines and fresh water could yield a power density of 1.2 W/m^2 (Fig. 4). Most promising power outputs were obtained with the same membranes and spacers as was the case for the seawater application [9]. A limit on applicable salt concentrations in the concentrated brines was suggested [10], which is in accordance with the observation that the power density has a non-linear response to increasing electrochemical potential (which is the result of a decreasing permselectivity with increasing salt concentrations, as explained later in the paper).

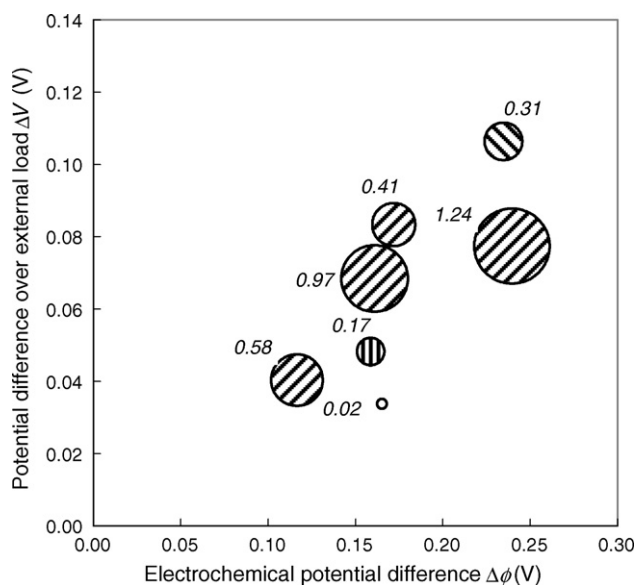

Fig. 4. Power densities (W/m^2) obtained with reverse electro dialysis (power density for total membrane area, i.e. both anion and cation exchange membranes); $\Delta\phi$ is the electrochemical potential difference, and ΔV the potential difference over the external load. Diameter of the bullets represents the power densities either reported (▨: Jagur-Grodzinski and Kramer [9]), or derived from reported potential, resistances and current (□: Pattle [4]; ▨: Weinstein and Leitz [12]; ▩: Audinos [27]).

2.2.3. Comparison of techniques

From the literature, one may suggest that the two techniques have their own field of application. Pressure-retarded osmosis may be preferable to convert salinity-gradient energy from mixing more concentrated brines with diluted solutions, whereas reverse electro dialysis may be preferable to convert salinity-gradient energy from mixing sea water with diluted solutions. However, such a conclusion is not well-founded for more than one reason:

1. For pressure-retarded osmosis, the efficiency losses due to conversion of hydrostatic potential energy to electrical energy by a turbine and generator were not taken into account, whereas for reverse electro dialysis the efficiency losses due to electrode reactions were taken into account.
2. Different mixtures of sodium chloride solutions were used. For pressure-retarded osmosis, generally, the salt concentrations of the diluted solutions were kept considerably low (pure water) whereas for reverse electro dialysis the salt concentrations of the diluted solutions were higher.
3. The only reported measure of performance for each technique is the obtained power or the power density (W/m^2) as shown in Figs. 3 and 4. However, the obtained power cannot be seen separately from the energy recovery. This energy recovery represents the amount of energy converted per volume of feed solutions (J/m^3).

A comparison of pressure-retarded osmosis and reverse electro dialysis using experimental data available from the literature is not sufficient as the conditions were not equal and the reported performances were incomplete. Therefore, we developed a method which allows for a better comparison under equal conditions, namely, on power density and energy recovery.

3. Methods

3.1. Assumptions

In order to compare pressure-retarded osmosis and reverse electro dialysis under equal conditions we developed a model in which each equation valid for pressure-retarded osmosis was compared to its equivalent for reverse electro dialysis. The following assumptions were made:

1. Feed solutions were assumed to consist of pure sodium chloride solutions. No distinction was made between concentrations and activities (i.e. ideal behavior). Mole fractions were used, which were defined as:

$$x_i = c_i \bar{V} \quad (1)$$

where i refers to the component under consideration, x the mole fraction, c the concentration (mol/m^3), and \bar{V} is the molar volume of the solution (m^3/mol). The molar volumes were derived from data on volumetric properties of aqueous sodium chloride [11]. Mole fractions which were mentioned

without subscript should be read as mole fractions of the dissolved sodium and chloride ions.

2. Sodium chloride solutions of different molarities were annotated as ‘river’, ‘sea’ and ‘brine’. They correspond to following sodium chloride concentrations: river 0.05 mol/l, sea 0.5 mol/l, and brine 5.0 mol/l.
3. The temperature of the solutions was 293 K.
4. The volumetric mixing rate of the concentrated solution to the diluted solution was 1:1.
5. Membranes were considered to behave ideal; pressure-retarded-osmosis membranes were only permeable to water and reverse-electrodialysis membranes were only permeable to salt ions (mainly for counter-ions, but to a limited extent also to co-ions).
6. We used the *gross* power density instead of the *net* power density, which means that internal efficiency losses (e.g. friction losses, pump and turbine efficiencies, electrochemical (over-) potentials) were not taken into account. For comparison of pressure-retarded osmosis and reverse electro dialysis, configuration specific efficiency losses were neglected, assuming that these did not account for a distinction between both techniques. For instance, external concentration polarization in both systems could be minimized by an appropriate cross-flow velocity.

3.2. Model

Several models are available, which are using many of the assumptions described in the previous section (for pressure-retarded osmosis, e.g. [3,7]; for reverse electro dialysis, e.g. [12]). In the present work we translated each equation valid for pressure-retarded osmosis into its equivalent for reverse electro dialysis in order to get a usable model for comparison at same conditions.

3.2.1. Energy from mixing salt and fresh water

The driving force for transport of a component is a gradient in free energy. The molar free energy (μ) of a component of an ideal solution can be written as follows (e.g. [13]):

$$\mu_i = \mu_i^0 + \bar{v}_i \Delta p + RT \ln x_i + |z_i| F \Delta \varphi \quad (2)$$

where μ^0 is the molar free energy under standard conditions (J/mol), \bar{v} the partial molar volume, Δp the pressure change compared to atmospheric conditions (Pa), R the gas constant (8.314 J/mol K), T the absolute temperature (K), z the valence of an ion (equiv./mol), F the Faraday constant (96,485 C/equiv.), and $\Delta \varphi$ is the electrical potential difference (V). The theoretical amount of free energy which can be obtained from mixing two solutions of different salinity can be calculated by using Eq. (2). Since there is no pressure change or charge transport, the total amount of energy can be determined from the chemical potential difference before mixing subtracted by the chemical potential after mixing. The free energy difference from mixing a concentrated and a diluted solution becomes:

$$E = \sum_i (E_{i,c} + E_{i,d} - E_{i,b}) = \sum_i (c_{i,c} V_c RT \ln(x_{i,c}) + c_{i,d} V_d RT \ln(x_{i,d}) - c_{i,b} V_b RT \ln(x_{i,b})) \quad (3)$$

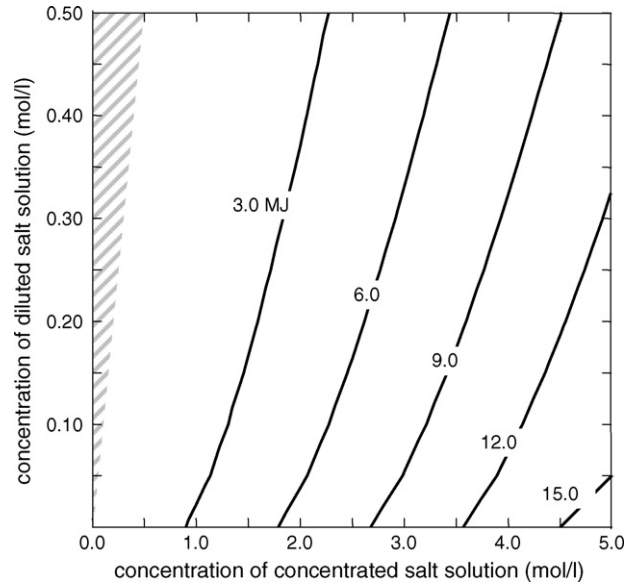

Fig. 5. Theoretically available amount of energy (MJ) from mixing 1 m³ of a diluted and 1 m³ of a concentrated sodium chloride solution ($T=293$ K). Shaded area: is kept out of consideration since here the salt concentration of the concentrated solution is lower than that of the diluted solution.

where E is the free energy (J) and V the volume (m³), c refers to the concentrated salt solution, d to the diluted salt solution, b to the brackish salt solution which remains after mixing. Often the free energy difference of the water is not taken into account (e.g. [14]), which results in an under-estimation of <10%.

The theoretically available amount of energy from mixing 1 m³ seawater (comparable to 0.5 mol/l NaCl) and 1 m³ river water (comparable to 0.01 mol/l NaCl) both at a temperature of 293 K is 1.5 MJ; the theoretically available amount of energy from mixing 1 m³ brine (5 mol/l NaCl) and 1 m³ river water (0.01 mol/l NaCl) at 293 K is more than 16.9 MJ. The theoretically available amount of energy for an extensive range of sodium chloride concentrations is presented in Fig. 5.

3.2.2. Driving force for pressure-retarded osmosis

Osmosis can only occur due to the presence of a semi-permeable membrane, which separates a concentrated solution (salt water) from a diluted solution (fresh water). This membrane allows the passage of water and retains the transport of ions. The driving force for the permeation of water is a difference in free energy between the salt and the fresh water side. This water transport is opposed by a higher hydrostatic pressure at the concentrated salt solution compartment. Water transport will continue until equilibrium is reached. Since there is no transport of ions ($|z_i| F \Delta \varphi = 0$) and to the diluted solution a hydrostatic pressure $\Delta p = 0$ is applied, Eq. (2) reduces at equilibrium conditions ($\mu_{\text{H}_2\text{O},c} = \mu_{\text{H}_2\text{O},d}$) to:

$$\bar{v}_{\text{H}_2\text{O},c} \Delta \pi + RT \ln(x_{\text{H}_2\text{O},c}) = RT \ln(x_{\text{H}_2\text{O},d}) \quad (4)$$

where $\Delta\pi$ is the osmotic pressure difference between both solutions (Pa). Since for sodium chloride solutions $\ln(x_{H_2O}) = \ln(1 - 2x) \approx 2 \ln(1 - x)$ and $\bar{v}_{H_2O,c} = \bar{v}$, Eq. (4) can be reduced to:

$$\Delta\pi = \frac{2RT}{\bar{v}} \ln \frac{1 - x_d}{1 - x_c} \quad (5)$$

The osmotic pressure difference between both solutions is the driving force for osmotic water transport. In pressure-retarded osmosis a hydrostatic pressure is applied at the saltwater side (ΔP , Pa), which reduces the driving force for water transport to $\Delta\pi - \Delta P$. The applied hydrostatic pressure difference should be less than the osmotic pressure ($\Delta P < \Delta\pi$) but can also be limited by the configuration of the system and the mechanical strength of the membrane ($\Delta P < \Delta P_{max}$, where ΔP_{max} is the maximum allowable hydrostatic pressure difference over the membrane). The transport of water through the membrane (Q , m^3/s) and the hydrostatic pressure difference (ΔP) can be used for power production by a turbine and generator (see Fig. 1).

3.2.3. Driving force for reverse electrodialysis

Ion transport in reverse electrodialysis can only occur due to the presence of perm-selective ion exchange membranes (i.e. cation exchange membranes and anion exchange membranes), which separate a concentrated solution from the diluted solution. These membranes allow the selective passage of ions and retain the transport of water. The driving force for the migration of ions is a difference in free energy between the concentrated and the diluted solution side. This ion transport will continue until equilibrium is reached. Since there is no transport of water and there is no pressure difference between both solutions (for both solution Δp is equal), Eq. (2) reduces at equilibrium conditions ($\mu_{NaCl,c} = \mu_{NaCl,d}$ and to both solutions an electrical potential $\Delta\phi$ is applied which equals their electrochemical potential ϕ) to:

$$\begin{aligned} & \frac{RT}{|z_{Na}|F} \ln(x_{Na,c}) + \frac{RT}{|z_{Cl}|F} \ln(x_{Cl,c}) \\ &= \frac{RT}{|z_{Na}|F} \ln(x_{Na,d}) + \frac{RT}{|z_{Cl}|F} \ln(x_{Cl,d}) + \Delta\phi \end{aligned} \quad (6)$$

where $\Delta\phi$ is the electrochemical potential difference between both solutions (V). Since for sodium chloride solutions $|z_{Na}| = |z_{Cl}| = 1$ and $x_{Na} = x_{Cl} = x$, Eq. (6) can be reduced to a Nernst-equation for an aqueous monovalent electrolyte:

$$\Delta\phi = \frac{2RT}{F} \ln \left(\frac{x_c}{x_d} \right) \quad (7)$$

The electrochemical potential difference between both solutions is the driving force for ion transport. Notice that, in practice, cell pairs are stacked and the electrochemical potential difference should be multiplied by the number of cell pairs. In reverse electrodialysis an electrical potential difference is applied over an external load ($N\Delta V_1$, V), which in case of one cell pair ($N = 1$, and thus $\Delta V = \Delta V_1$), reduces the driving force for ion transport to $\Delta\phi - \Delta V$. The charge transport through the membranes (I ,

C/s) and the applied potential difference (ΔV) result in a power production (see Fig. 2).

3.2.4. Molar flux of pressure-retarded osmosis

In practice, the apparent driving force for water transport in pressure-retarded osmosis deviates from $\Delta\pi - \Delta P$. The driving force seems not to be determined by the osmotic pressure difference of the bulk solutions, but by the osmotic pressure difference over the semi-permeable skin (see Fig. 6). In other words, the driving force needs to be corrected for the internal concentration polarization occurring in the porous support layer at the fresh water side [3,7,15]. This corrected osmotic pressure difference is given by:

$$\Delta\pi_{eff} = \pi_c - \pi_d \exp(J_w k) \quad (8)$$

where $\Delta\pi_{eff}$ is the corrected or effective osmotic pressure difference over the semi-permeable skin (Pa), J_w the volumetric water flux (m/s), and k the transport resistance to a salt in the porous support layer (s/m). In practice, the internal concentration polarization is also determined by salt diffusion through the skin from the concentrated salt solution to the diluted salt solution. However, this salt diffusion is excluded from the model assuming ideal behavior of the membranes.

The molar flux J_{H_2O} (mol/m² s) can be calculated from the volumetric water flux J_w , as measured on the membrane side facing the concentrated salt solution, according to the relation-

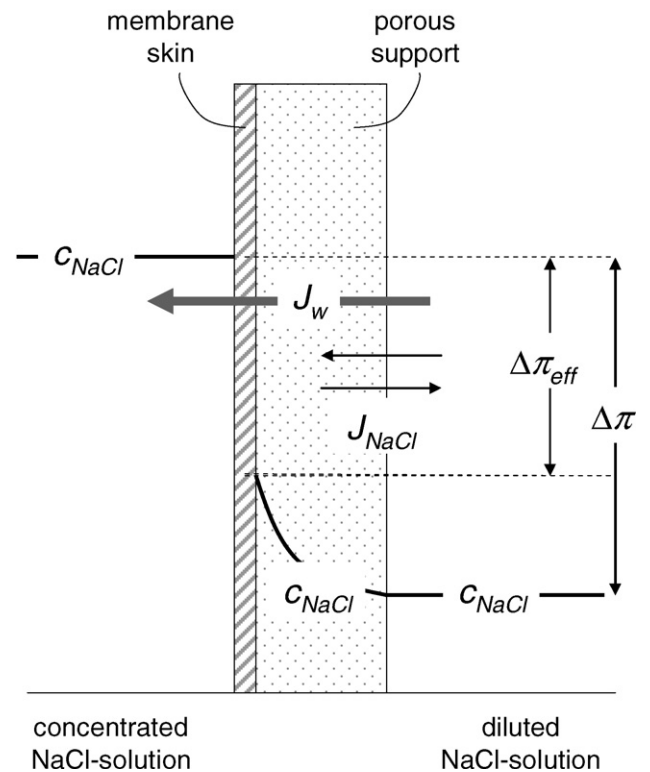

Fig. 6. Schematic representation of apparent driving force of pressure-retarded osmosis ($\Delta\pi_{eff}$), which deviates from the osmotic pressure difference of the bulk solutions ($\Delta\pi$) due to concentration polarization in the porous support. J_w and J_{NaCl} are fluxes of water and salt, c the salt concentration. Salt diffusion through the membrane skin is excluded by the assumption of ideal membrane behavior.

ship:

$$J_{\text{H}_2\text{O}} = \frac{J_w}{\bar{V}_c} = \frac{A_w(\Delta\pi_{\text{eff}} - \Delta P)}{\bar{V}_c} \quad (9)$$

where A_w is the water permeation coefficient of the membrane (m/Pa s) at actual $\Delta\pi$ and hydrostatic pressure difference over the membrane ΔP . This permeation coefficient does not have a constant value (see Section 4.3), but it can be related to the absolute average of the mole fractions on both sides of the membrane and the hydrostatic pressure [16]. In order to define such correlations for the water permeation coefficient an appropriate number of data points should be used. For this reason the data for a hollow-fiber TFC PA membrane of Mehta and Loeb [8] was used. For this type of membrane a correlation was found for the water permeation coefficient A_w with only the osmotic pressure difference of both (bulk) solutions, according to:

$$A_w = i(\Delta\pi \times 10^{-5})^j \quad (10)$$

where i and j are correlation coefficients which can be derived from pressure-retarded osmosis experiments and direct osmosis experiments.

3.2.5. Molar flux of reverse electrodialysis

In practice, the apparent driving force for charge transport in reverse electrodialysis deviates from $\Delta\phi - \Delta V$. The driving force seems not to be determined by the electrochemical potential difference between the bulk solutions, but by the sum of the Donnan-potentials of the membrane solution interfaces. In other words, the driving force needs to be corrected for the mole fraction of the free counter-ions within the membrane matrix at both interfaces ($x_{m,c}$ and $x_{m,d}$). This corrected electrochemical potential difference can be calculated with:

$$\begin{aligned} \Delta\phi_{\text{eff}} &= \alpha\Delta\phi = \frac{2RT}{F} \left(\ln \left(\frac{x_c}{x_{m,c}} \right) + \ln \left(\frac{x_{m,d}}{x_d} \right) \right) \\ &= \frac{2RT}{F} \ln \left(\frac{x_c \left(\bar{x} + \sqrt{4x_d^2 + \bar{x}^2} \right)}{x_d \left(\bar{x} + \sqrt{4x_c^2 + \bar{x}^2} \right)} \right) \end{aligned} \quad (11)$$

where $\Delta\phi_{\text{eff}}$ is the so-called membrane potential (V), which is in fact the corrected or mean effective electrochemical potential difference over the anion and cation exchange membrane, \bar{x} the mean mole fraction of the active groups of the ion exchange membranes, α the perm selectivity coefficient. This perm selectivity coefficient reflects the discrimination between counter-ions and co-ions by the ion exchange membrane in given solutions [12]. Eq. (11) generally is expressed in molarities (c) instead of mole fractions (x), e.g. [17].

The molar flux of sodium chloride J_{NaCl} (mol/m² s) can be calculated from the charge flux J_i (i.e. the current density, A/m²) divided by the Faraday constant, according to the relationship:

$$J_{\text{NaCl}} = \frac{J_i}{F} = \frac{1}{Fr} (\Delta\phi_{\text{eff}} - \Delta V) \quad (12)$$

where r is the internal area resistance ($\Omega \text{ m}^2$) of a cell pair consisting of a cation exchange membrane, a compartment filled

with a concentrated salt solution, an anion exchange membrane, and a compartment filled with a diluted salt solution (Fig. 2). The internal area resistance of a cell pair can be calculated from the sum of the area resistance of the membranes and that of both solutions:

$$r = r_C + \frac{h_c \bar{V}_c}{\lambda_c x_c} + r_A + \frac{h_d \bar{V}_d}{\lambda_d x_d} \quad (13)$$

where r_C is the area resistance of the cation exchange membrane ($\Omega \text{ m}^2$), h the compartment or spacer width (m), λ the equivalent conductance ($\text{m}^2/\Omega \text{ mol}$), and r_A is the area resistance of the anion exchange membrane ($\Omega \text{ m}^2$)

3.2.6. Power density of pressure-retarded osmosis

For pressure-retarded osmosis, the power density W (W/m²) is equal to the product of the volumetric water flux and the hydrostatic pressure difference over the membrane:

$$W^{\text{PRO}} = J_w \Delta P = A_w (\Delta\pi_{\text{eff}} - \Delta P) \Delta P \quad (14)$$

The optimal power density can be derived from differentiating Eq. (14) with respect to the hydrostatic pressure difference over the membrane (ΔP). Neglecting internal concentration polarization (i.e. $k=0$ s/m), the optimal power output is obtained when ΔP equals $\Delta\pi_{\text{eff}}/2$. Substitution of this value for ΔP and the effective osmotic pressure difference results in the following equation for the optimal power density obtainable in pressure-retarded osmosis:

$$W_{\text{opt}}^{\text{PRO}} = A_w \frac{\Delta\pi_{\text{eff}}^2}{4} \quad (15)$$

This optimal power density, however, is not always achievable in practice. The applied hydrostatic pressure difference can be limited by the configuration of the system and the mechanical strength of the membrane. In case $\Delta\pi_{\text{eff}}/2 > \Delta P_{\text{max}}$, the (sub)optimal power density is given by Eq. (14) with $\Delta P = \Delta P_{\text{max}}$ (instead of by Eq. (15)).

3.2.7. Power density of reverse electrodialysis

For reverse electrodialysis, the power density W (W/m²) is defined as the power generated per unit of total membrane area. This power density is equal to the product of half the current density (i.e. current passing area contains both cation and anion exchange membrane) and the potential difference over an external load:

$$W^{\text{RED}} = \frac{J_i}{2} \Delta V = \frac{1}{2r} (\Delta\phi_{\text{eff}} - \Delta V) \Delta V \quad (16)$$

The optimal power density can be derived from differentiating Eq. (16) with respect to the potential difference over the external load (ΔV). As a result the optimal power output is obtained when ΔV equals $\Delta\phi_{\text{eff}}/2$. This is the case when the resistance of the external load or power consumer equals the internal resistance of the reverse electrodialysis cell pair. Substitution of this ΔV and the membrane potential results in the following equation for the optimal power density obtainable in

reverse electro dialysis:

$$W_{\text{opt}}^{\text{RED}} = \frac{1}{2r} \frac{\Delta\phi_{\text{eff}}^2}{4} \quad (17)$$

3.2.8. Maximum and average power density of both techniques

Like in literature, the model calculated up to this point the optimized power density at a given concentrations of the diluted and concentrated salt solutions. Systems in literature are continuously fed and are optimized with respect to power density in a steady state.

These systems are operated with a short residence time such that no appreciable changes in the concentrations take place. A small change in concentration means that only a very small part of the available mixing energy is used. In practice, however, one wants to use a considerable fraction of the available energy. Consequently, the concentrations will change appreciably and thus the driving force and power density. Therefore, a proper evaluation of the power density must take these changing concentrations into account.

To illustrate this, we will analyze a co-current operation and investigate the effect of the residence time on the power density. It is expected that with increasing residence time the power density decreases and the energy recovery increases. Hence, if the optimal power density is evaluated over a time period ($t - t_0$) a *maximum* power density exists:

$$W_{\text{max}} = \max(W_{\text{opt},t_0} : W_{\text{opt},t}) \quad (18)$$

Over the same time period also a (time) *average* power density can be defined:

$$W_{\text{average}} = \frac{\int_{t_0}^t W_{\text{opt}} dt}{t - t_0} \quad (19)$$

3.2.9. Energy recovery of both techniques

The residence time also determines the exhaustion of the available energy. Therefore, also the energy recovery can be evaluated over time. The energy recovery η (%) is calculated as the ratio of power produced over the time interval ($t - t_0$) to the amount of free energy E at initial conditions (at time t_0 ; see Eq. (3)):

$$\eta = \frac{\int_{t_0}^t (W_{\text{opt}} A_m) dt}{E} \times 100\% \quad (20)$$

where A_m is the applied membrane surface. If the time period is infinite small, the energy recovery will be close to 0%. In accordance with the above, the energy recovery will be close to 0% when the system is operating at the maximum power density.

3.3. Performance indicators

For evaluation, two measures of performance can be calculated with the present model: power density (W/m^2) and energy recovery (%). However, as power density and energy recovery are both determined by the residence time, we define the perfor-

mance indicators for comparison of the techniques more strictly. Two performance indicators are distinguished:

1. The *maximum* power density as calculated with Eq. (18). This measure was also reported in the literature (or can be derived from presented data). In general, the maximum power density is achieved under initial process conditions, i.e. from mixing the original feed solutions (energy recovery $\eta \approx 0\%$). Consequently, the maximum power density can be evaluated separately from the energy recovery.
2. The *average* power density (Eq. (19)) at a specified energy recovery (Eq. (20)). For a given design and operation, the residence relates the energy recovery and the average power density. In Section 4, therefore, the average density is expressed as a function of the energy recovery. The average power density generally decreases with an increase of energy recovery. The average power density cannot be seen separately from the energy recovery.

4. Results and discussion

4.1. Comparison based on published system characteristics

The input values for the model calculations consist of system characteristics for both pressure-retarded osmosis and reverse electro dialysis. These characteristics can be obtained from the literature referred to in the theoretical section. In this way the model calculations can be considered as an approximation of the state-of-the-art of both techniques.

4.1.1. System characteristics

For pressure-retarded osmosis, membrane characteristics are derived from Mehta and Loeb [8] using a fit of Eq. (10) through the data points. The water permeation coefficient of the polyamide membranes used in this reference can be correlated to $\Delta\pi$ according to $i = 4.8 \times 10^{-12}$ and $j = -0.8$ (i.e. $A_w = 4.8 \times 10^{-12} (\Delta\pi \times 10^{-5})^{-0.8}$). The transport resistance for sodium chloride in the porous support layer is estimated to be equal to the transport resistance for a thin film composite membrane, $k = 10 \text{ d}/\text{m} = 9 \times 10^5 \text{ s}/\text{m}$ [18], which seems to be an optimistic but reasonable value. The maximum allowable hydrostatic pressure difference is chosen to be $\Delta P_{\text{max}} = 60 \text{ bar} = 60 \times 10^5 \text{ Pa}$ since this value does not exceed all values in the experiments presented in Fig. 3.

For reverse electro dialysis, membrane characteristics are obtained from Jagur-Grodzinski and Kramer [9]. From their measurements of membrane perm selectivity (α), the charge density of the membranes (\bar{c}) is estimated to be $3 \times 10^3 \text{ equiv.}/\text{m}^3$ by using Eq. (11). A typical value reported for the membrane resistance (r_m) is $3 \Omega \text{ cm}^2 = 3 \times 10^{-4} \Omega \text{ m}^2$ (in a 0.5 mol/l NaCl solution). The minimum compartment or spacer width which is applied in reverse electro dialysis is $6.5 \times 10^{-4} \text{ m}$ [9].

4.1.2. Maximum power density

By using the model equations and the membrane characteristics reported in the literature, the maximum power density can be calculated (Eq. (18)). For both techniques the results are pre-

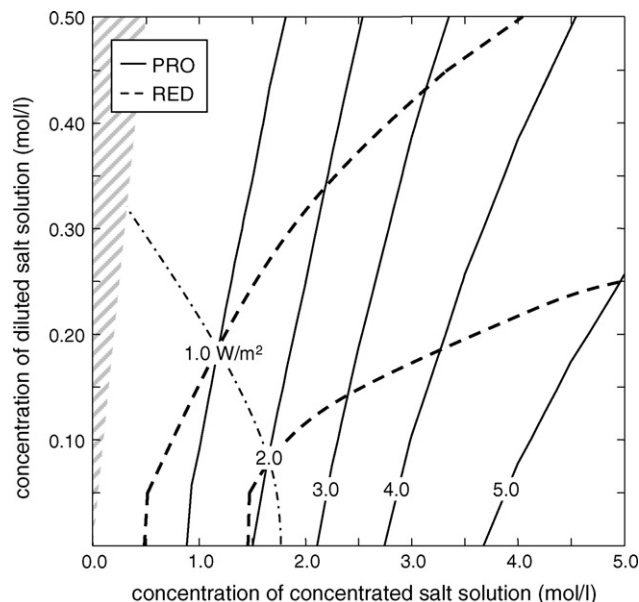

Fig. 7. Calculated maximum power density (W/m^2) for pressure-retarded osmosis (PRO) and reverse electro dialysis (RED) using published membrane characteristics. Below the break-even-line (dash-dot-line) reverse electro dialysis has a higher maximum power density than pressure-retarded osmosis; above the break-even-line the opposite is true. Shaded area: is kept out of consideration since here the salt concentration of the concentrated solution is lower than that of the diluted solution.

sented in Fig. 7. For applications on seawater and river water, current reverse electro dialysis seems to have a higher maximum power density than pressure-retarded osmosis. For applications on brines, maximum power densities obtained with pressure retarded osmosis are higher than for reverse electro dialysis.

The contour lines in Fig. 7 show that the maximum power density of reverse electro dialysis is more sensitive to the concentration of the diluted solution and less sensitive to the concentration of the concentrated solution (i.e. more horizontal orientated isohypses), when compared to pressure-retarded osmosis which is more sensitive to the concentration of the concentrated solution. For both techniques, however, the same trends can be observed, that is a non-linear response of the maximum power density to an increase in concentration of the concentrated salt solution. From a sensitivity analysis we found that for pressure-retarded osmosis this non-linear response at higher concentrations of the concentrated solutions is mainly determined by the limitation of the applied hydrostatic pressure difference ($\Delta P_{\max} < \Delta \pi_{\text{eff}}/2$). For reverse electro dialysis, the response of the maximum power density to the concentration of the concentrated salt solution is mainly determined by the negative effect of the decrease in perm selectivity on the membrane potential ($\Delta \phi_{\text{eff}} \ll \Delta \phi$, Eq. (11)) and thus on optimal power density (Eq. (17)), more than by a positive effect of the decrease in internal resistance (Eq. (13)) on optimal power density.

4.1.3. Average power density at variable energy recovery

In general, the maximum power density is achieved at (almost) initial concentrations for both feed solutions. If mixing

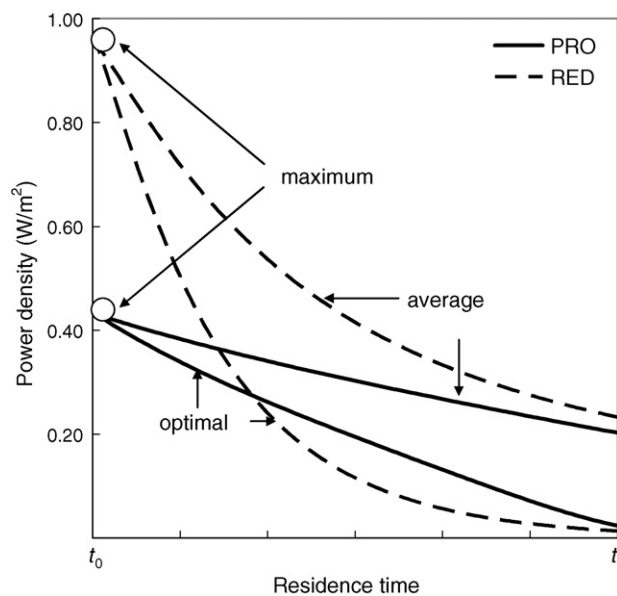

Fig. 8. Calculated maximum and average power density for pressure-retarded osmosis (PRO) and reverse electro dialysis (RED) based on published membrane characteristics, for mixing sea water (0.5 mol/l NaCl) with river water (0.05 mol/l NaCl).

continues, the optimal power density will decrease. The decrease of the optimal power density with residence time for mixing seawater with river water is presented in Fig. 8. The area below the curve of the optimal power density represents the amount of energy converted as explained by Eq. (20). The amount of energy converted (and thus the energy recovery) increases with time.

From Fig. 8 it can be seen that although the maximum power density of reverse electro dialysis is twice the maximum power density of pressure-retarded osmosis, at the end the average power density (Eq. (19)) is almost the same after conversion of the same amount of energy (i.e. almost the same area under the curve of the optimal power densities for both techniques). In other words, this confirms that the power density should be considered in combination with energy recovery as in Fig. 9.

Fig. 9 shows that the maximum energy recovery seems to be 50%. This can be explained by the fact that both techniques operate at optimal power density when the spontaneous mixing is retarded by a back-force which is half the effective driving force (Eqs. (15) and (17), where $\Delta P = \Delta \pi_{\text{eff}}/2$ and $\Delta V = \Delta \phi_{\text{eff}}/2$). In theory the energy recovery could come close to 100% once the mixing is retarded by a back-force which almost equals the effective driving force ($\Delta P \rightarrow \Delta \pi_{\text{eff}}$ and $\Delta V \rightarrow \Delta \phi_{\text{eff}}$). In this case, however, the achieved power density will be close to zero, according to Eqs. (14) and (16). In the same way the energy recovery theoretically could be lower than 50% when the mixing is less retarded by a back-force ($\Delta P < \Delta \pi_{\text{eff}}/2$ and $\Delta V < \Delta \phi_{\text{eff}}/2$). The achieved power density will then also be lower than the optimal power density (Eqs. (14) and (16)).

For mixing seawater and river water, the techniques come close to an energy recovery of 50%; the maximum energy

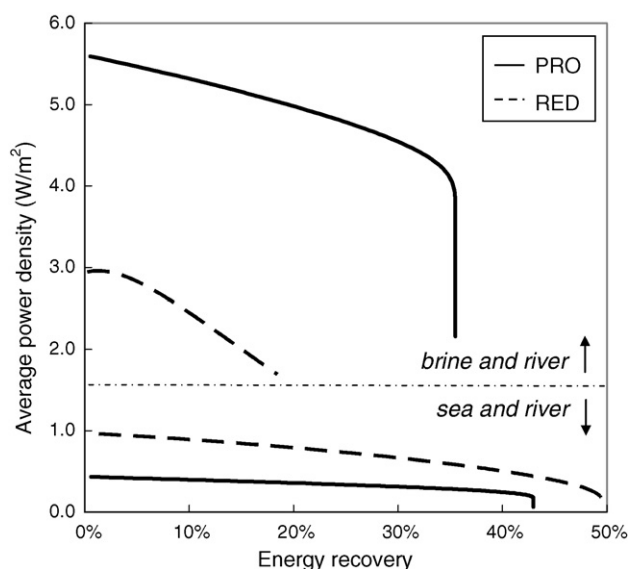

Fig. 9. Calculated average power density and energy recovery for pressure-retarded osmosis (PRO) and reverse electrodialysis (RED) using currently available membrane characteristics, for mixing seawater (0.5 mol/l NaCl) with river water (0.05 mol/l NaCl) and for mixing brine (5 mol/l NaCl) with river water.

recovery of pressure-retarded osmosis is 43% and the maximum energy recovery of reverse electrodialysis is 49%. These somewhat lower energy recovery rates are caused by irreversible mixing due to internal concentration polarization (pressure-retarded osmosis, $\Delta\pi_{\text{eff}} < \Delta\pi$) or a perm selectivity being less than unity caused by transport of co-ions (reverse electrodialysis, $\Delta\phi_{\text{eff}} < \Delta\phi$). Both average power density and energy recovery are higher for reverse electrodialysis than for pressure-retarded osmosis.

For application on brine, the obtained results are more complex. It is clear that both the average power density and the energy recovery are higher for pressure-retarded osmosis than for reverse electrodialysis. Especially for reverse electrodialysis, the energy recovery is considerably lower than 50%; the maximum energy recovery of pressure-retarded osmosis is 36% and the maximum energy recovery of reverse electrodialysis is even lower. These lower energy recovery rates are mainly caused by limitations in the applied hydrostatic pressure difference (pressure-retarded osmosis, $\Delta P_{\text{max}} < \Delta\pi_{\text{eff}}/2$) or by irreversible mixing due to a significant perm selectivity loss (reverse electrodialysis, $\Delta\phi_{\text{eff}} < \Delta\phi$).

Both techniques have different profiles of the average power density–energy recovery curve. The sharp profile of the curve of pressure-retarded osmosis shows that at maximum energy recovery still a relative high average power density is obtained.

So, for power generation from mixing seawater and river water with currently available membranes, results show a better performance for reverse electrodialysis than for pressure-retarded osmosis, both on power density (maximum and average) and energy recovery. For power generation from mixing a brine and less concentrated water, the opposite is true. These conclusions are in accordance to what already was suggested from the literature review.

4.2. Potential of both techniques

The derived model calculations can also be used to show the potential of these techniques by using favorable but realistic estimates for the system characteristics.

4.2.1. System characteristics

For pressure-retarded osmosis, according to predictions of Lee et al. [7] membrane characteristics of cellulose acetate membranes would be the most promising. They have predicted a power density of 1.54 W/m^2 for applications on sea and river water. The characteristics of a cellulose acetate membrane can be estimated using the data of Mehta [6] from which one may derive that the water flux is almost independent of the osmotic pressure difference, i.e. $j = -1$. Assuming $j = -1$, from the predicted power density of 1.54 W/m^2 it can be estimated that $i = 2.2 \times 10^{-11}$ (i.e. $A_w = 2.2 \times 10^{-11} (\Delta\pi \times 10^{-5})^{-1}$). The maximum allowable hydrostatic pressure difference can be obtained from common seawater desalination applications where ΔP_{max} is $80 \times 10^5 \text{ Pa}$. Loeb [19] suggested that the transport resistance of the support can be limited to $k = 1 \times 10^5 \text{ s/m}$.

For reverse electrodialysis, a membrane charge density of 3 equiv./m^3 and a membrane resistance r_m of $0.5 \Omega^2 \text{ cm}^2 = 5 \times 10^{-5} \Omega \text{ m}^2$ is realistic. The minimum compartment or spacer width which can be applied without excessive friction losses, can be $0.25 \times 10^{-3} \text{ m}$ (or even lower) since the cross flow velocity can be 100 times lower than for normal electrodialysis [9].

4.2.2. Maximum power density

By using the model equations and favorable membrane characteristics, the potential maximum power density can be calculated (Eq. (18)). The results are presented in Fig. 10. The calculated maximum power densities for both systems are now comparable over the whole range of concentrations, varying from 2 to 10 W/m^2 . For applications on seawater and river water, reverse electrodialysis has a higher potential maximum power density than pressure-retarded osmosis ($2\text{--}4 \text{ W/m}^2$ versus $<2 \text{ W/m}^2$). For pressure-retarded osmosis, the maximum power density from the model is 1.2 W/m^2 , which is less than the expected 1.54 W/m^2 for a cellulose acetate membrane predicted by Lee et al. [7]. This difference, however, is due to the use of a lower seawater concentration in the model compared to the literature (0.5 instead of 0.6 mol/l NaCl).

For applications on brines, maximum power densities are comparable for both techniques ($>10 \text{ W/m}^2$). Pressure-retarded osmosis seems to be less sensitive to the concentration of the diluted solution than reverse electrodialysis which is a benefit of pressure-retarded osmosis when the energy recovery is taken into account.

4.2.3. Average power density at variable energy recovery

The average power density and energy recovery are presented in Fig. 11. For mixing seawater and river water, the average power density at certain energy recovery is higher for reverse electrodialysis than for pressure-retarded osmosis. Both techniques come close to a energy recovery of 50%, which

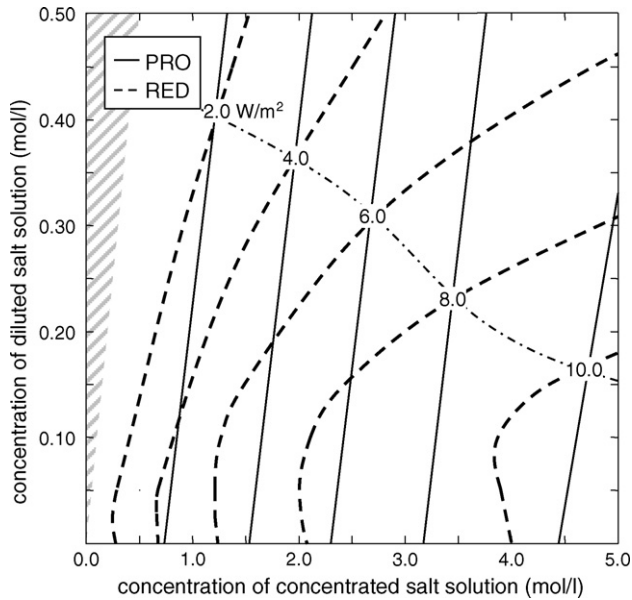

Fig. 10. Calculated potential maximum power density (W/m^2) for pressure-retarded osmosis (PRO) and reverse electro dialysis (RED) using best membrane characteristics. Below the break-even-line (dash-dot-line) reverse electro dialysis has a higher maximum power density than pressure-retarded osmosis; above the break-even-line the opposite is true. Shaded area: is kept out of consideration since here the salt concentration of the concentrated solution is lower than that of the diluted solution.

is explained earlier. Irreversible mixing can now be neglected since internal concentration polarization hardly exists (pressure-retarded osmosis) or perm selectivity is close to unity (reverse electro dialysis).

For application on brine, the average power density at certain energy recovery generally is higher for pressure-retarded osmosis than for reverse electro dialysis. For pressure-retarded osmosis, the energy recovery is hardly limited by internal

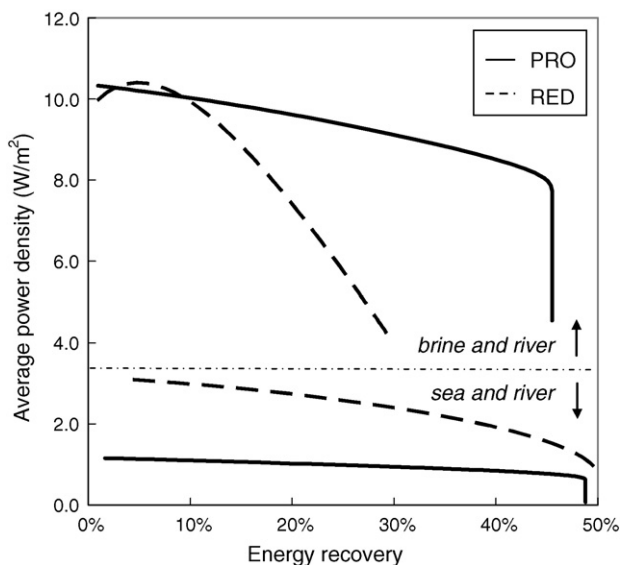

Fig. 11. Calculated average power density and energy recovery for pressure-retarded osmosis (PRO) and reverse electro dialysis (RED) using best-available system characteristics, for mixing seawater (0.5 mol/l NaCl) with river water (0.05 mol/l NaCl) and for mixing brine (5 mol/l NaCl) with river water.

concentration polarization or the applied hydrostatic pressure difference (energy recovery close to 50%). For reverse electro dialysis, the energy recovery is relatively low (<30%) and the average power density is rapidly decreasing with increasing energy recovery. Both techniques have different profiles of the average power density–energy recovery curve. The curve of reverse electro dialysis shows a maximum value which indicates that the initial conditions that after some mixing the decrease in internal resistance (Eq. (13)) is higher than the decrease in potential (Eq. (11)), which results in an increase of the optimal power density (Eq. (17)).

So, for power generation from mixing seawater and river water the potential of reverse electro dialysis is higher than for pressure-retarded osmosis, both on power density (maximum and average) and energy recovery. For power generation from mixing a brine and less concentrated water, the opposite is true. The potential performances of both techniques are much higher than current performances (see Section 4.1). In order to achieve these potential performances, the development of pressure-retarded osmosis must focus on membrane characteristics, i.e. increasing the water permeability of the membrane skin and optimization of the porous support. The development of reverse electro dialysis, however, must focus on system characteristics, i.e. optimization of the internal resistance, which is mainly determined by the width of the spacers.

4.3. Discussion

4.3.1. Behavior of pressure-retarded osmosis membranes

In our model the fit function for the permeation coefficient A_w (Eq. (10)) seems to have a key-role in the model calculations for pressure-retarded osmosis. This can be seen as unsatisfactory, but it represents in our view the best practical approach. Also in literature, there is still a discussion on the not-well-understood behavior of osmosis membranes under pressure-retarded osmosis conditions with respect to permeability. From the beginning in 1976 [20], a major topic of research was to define an appropriate correlation between the osmotic pressure difference and the hydrostatic pressure difference on the one hand, and the water flux on the other, because this correlation defines the power output of the system. The correlation factor was defined as the permeation coefficient A_w . This permeation coefficient, however, seemed to be not a constant, and therefore was still subject of recent studies [16,21]. A number of mechanisms which could be responsible for the non-linear behavior was mentioned in the literature: ‘osmotic deswelling’ or ‘osmotic dehydration’ of the membranes at high osmotic pressures [8], cavitation and partial clogging [22]. Although the mechanisms are not yet well understood, it was concluded that this permeation coefficient itself could be related to the absolute average of the mol fractions of the solutes in the feed solutions and to the hydrostatic pressure [16]. However, from the limited amount of data available, we were not able to define an appropriate correlation factor between the permeation coefficient and the hydrostatic pressure. Therefore, in the present work the permeation coefficient is only correlated to the osmotic pressure difference according to Eq. (10).

4.3.2. Evaluation of practical behavior (fouling)

Besides the power density and the energy recovery, the practical behavior of both systems when applied to real surface waters also is a key-indicator. A good measure for this could be the sensitivity towards fouling. For pressure-retarded osmosis, there is no literature which deals with this aspect. However, it should be noticed that several references reported a permanent damage of the membranes in contact with high concentrated saline brines [8,20]. From desalination experiences with reverse osmosis one could expect a serious impact of (bio)fouling when pressure-retarded osmosis is applied to real sea water and real river water. For reverse electro dialysis, we found only one reference in which a fouling experiment was carried out. It was suggested that bio-film growth might have a significant negative effect on power density [23]. However, one could expect less impact of (bio)fouling on performances of reverse electro dialysis when compared to pressure-retarded osmosis since from comparable desalination experiences it is claimed that electro dialysis membranes are generally less sensitive to fouling than reverse osmosis membranes (e.g. electro dialysis has lower pre-treatment requirements and membranes are more chemical-resistant [24]).

4.3.3. Comparison of engineered and well-operated systems

The assumption that differences in specific efficiency losses can be neglected for the comparison between pressure-retarded osmosis and reverse electro dialysis may be subject to discussion. The different forms of loss can have considerably different kinds of effect to pressure-retarded osmosis than to reverse electro dialysis. For example, each system has a different optimal flow velocity which is a result of the balance between pressure losses and external concentration polarization. These differences in turn should in a real system result in differences in the optimal configuration of the membrane module (length, channel width (or diameter), packing density etc.) and the optimal operating conditions (e.g. mixing rate). For the sake of simplicity, in our model we assumed a co-current system which is not necessarily applied in practical operation. Therefore, in future work it would be worthwhile to compare the performances of two well-engineered and optimal operated systems.

4.3.4. Evaluation of costs

Capital costs and costs of operation and maintenance are probably the most important for evaluation of both techniques. However, since both techniques are still in the development stage, we were not able to perform realistic cost calculations. In order to make an estimation of the economic aspects, again we could make a comparison with the equivalent desalination techniques. The membrane area costs for currently available membranes for electro dialysis are two to three times higher than for reverse osmosis. The *installed* area costs (including membranes, pumps, pressure vessels, turbines, etc.), however, are in the same order of magnitude. From this one could expect that costs of reverse electro dialysis and pressure-retarded osmosis will not make distinction. Nevertheless, we assume that once the new membrane market for power production is emerging,

membrane prizes for especially (reverse) electro dialysis will be reduced tremendously since electro dialysis has never had a real breakthrough in the desalination market [25].

5. Conclusions

There is a huge potential to obtain clean energy from mixing water streams with different salt concentrations. All techniques currently available for desalination can be used to generate power from salinity gradients. Our objective was to evaluate and to compare the technical performance of the two membrane-based energy conversion techniques: pressure-retarded osmosis and reverse electro dialysis. A comparison based on the literature was not sufficient since the reported performances were incomplete (the power output was not related to energy recovery) and the measurement conditions were not comparable. A method was developed which allows a comparison of both techniques at equal conditions, both with respect to power density and energy recovery.

Based on the results from the model calculations, it can be concluded that each technique has its own field of application. Pressure-retarded osmosis seems to be more attractive for power generation using concentrated saline brines because of the higher power density combined with higher energy recovery. For the same reason reverse electro dialysis seems to be more attractive for power generation using seawater and river water. These conclusions are valid for both present and latent performances of both techniques.

According to the model, the potential performances of both techniques are much better than the current performances. In order to achieve these potential performances, the development of pressure-retarded osmosis must focus on membrane characteristics, i.e. increasing the water permeability of the membrane skin and optimization of the porous support. The development of reverse electro dialysis, however, must focus on system characteristics, i.e. optimization of the internal resistance, which is mainly determined by the width of the spacers.

Besides the power density and energy recovery, the practical behavior or the sensitivity for fouling is a key-indicator which should be investigated. Furthermore, the feasibility of these techniques will mainly depend on reduced membrane prices. It is believed that the membrane prices, especially for reverse electro dialysis, will decrease significantly once a new membrane market for power generation emerges. Therefore, it is worthwhile to further investigate and develop both membrane techniques in order to make sustainable conversion of salinity-gradient energy available for the future.

Nomenclature

A_m	membrane area (m^2)
A_w	water permeation coefficient ($m/s Pa$)
c	concentration (mol/m^3)
\bar{c}	charge density of (monovalent) functional groups ($equiv./m^3 = mol/m^3$)

E	energy (J)
F	Faraday constant (96,485 C/mol)
$J_{\text{H}_2\text{O}}$	molar water flux ($\text{mol}/\text{m}^2 \text{ s}$)
J_i	charge flux or current density ($\text{C}/\text{m}^2 \text{ s} = \text{A}/\text{m}^2$)
J_{NaCl}	molar salt flux ($\text{mol}/\text{m}^2 \text{ s}$)
J_w	volumetric water flux ($\text{m}^3/\text{m}^2 \text{ s} = \text{m}/\text{s}$)
h	width (height) of spacer (m)
i, j	correlation coefficients (dependent)
k	resistance to salt diffusion through porous substrate (s/m)
N	number of cell pairs
Δp	static pressure difference compared to standard static pressure (Pa)
ΔP	hydrostatic pressure difference between solutions (Pa, in figures: bar)
Q	volumetric water flow (m^3/s)
r	area resistance ($\Omega \text{ m}^2$)
R	universal gas constant (8.314 J/mol K)
t	time (s)
T	temperature (K)
\bar{v}	partial molar volume (m^3/mol)
V	volume (m^3)
\bar{V}	molar or specific volume of solution (m^3/mol)
ΔV	potential difference over external load (V)
W	power density (W/m^2)
x	mole fraction
\bar{x}	mole fraction of (monovalent) functional groups
Z	valence of ions (equiv./mol)

Greek letters

α	perm selectivity
η	energy recovery (%)
λ	equivalent conductance ($\text{m}^2/\Omega \text{ mol}$)
μ	molar free energy (J/mol)
$\Delta\pi$	osmotic pressure difference (Pa, in figures: bar)
$\Delta\phi$	electrical potential difference (V)
$\Delta\phi$	electrochemical potential difference between solutions (V)

Subscripts

b	brackish solution
c	concentrated solution
d	diluted solution
eff	effective
i	current (in J_i)
i	component i (all other cases)
m	membrane
max	maximum
opt	optimal under given conditions
w	water

Superscripts

PRO	pressure-retarded osmosis
RED	reverse electro dialysis

References

- [1] G.L. Wick, W.R. Schmitt, Prospects for renewable energy from sea, Mar. Technol. Soc. J. 11 (5–6) (1977) 16–21.
- [2] R.S. Norman, Water salination—source of energy, Science 186 (4161) (1974) 350–352.
- [3] S. Loeb, Production of energy from concentrated brines by pressure-retarded osmosis. 1. Preliminary technical and economic correlations, J. Membr. Sci. 1 (1) (1976) 49–63.
- [4] R.E. Pattle, Production of electric power by mixing fresh and salt water in the hydroelectric pile, Nature 174 (4431) (1954) 660–1660.
- [5] M. Olsson, G.L. Wick, J.D. Isaacs, Salinity gradient power—utilizing vapor-pressure differences, Science 206 (4417) (1979) 452–454.
- [6] G.D. Mehta, Further results on the performance of present-day osmotic membranes in various osmotic regions, J. Membr. Sci. 10 (1) (1982) 3–19.
- [7] K.L. Lee, R.W. Baker, H.K. Lonsdale, Membranes for power-generation by pressure-retarded osmosis, J. Membr. Sci. 8 (2) (1981) 141–171.
- [8] G.D. Mehta, S. Loeb, Performance of permasep b-9 and b-10 membranes in various osmotic regions and at high osmotic pressures, J. Membr. Sci. 4 (3) (1979) 335–349.
- [9] J. Jagur-Grodzinski, R. Kramer, Novel process for direct conversion of free-energy of mixing into electric-power, Ind. Eng. Chem. Process Des. Dev. 25 (2) (1986) 443–449.
- [10] R.E. Lacey, Energy by reverse electro dialysis, Ocean Eng. 7 (1) (1980) 1–47.
- [11] D.R. Lide, Handbook of Chemistry and Physics, 85th ed., CRC Press, 2004.
- [12] J.N. Weinstein, F.B. Leitz, Electric-power from difference in salinity—dialytic battery, Science 191 (4227) (1976) 557–559.
- [13] H. Strathmann, Ion-Exchange Membrane Separation Processes, 1st ed., Elsevier, 2004.
- [14] C. Forgacs, Recent developments in the utilization of salinity power, Desalination 40 (1–2) (1982) 191–195.
- [15] G.D. Mehta, S. Loeb, Internal polarization in the porous substructure of a semipermeable membrane under pressure-retarded osmosis, J. Membr. Sci. 4 (2) (1978) 261–265.
- [16] A. Seppala, M.J. Lampinen, On the non-linearity of osmotic flow, Exp. Thermal Fluid Sci. 28 (4) (2004) 283–296.
- [17] T. Sata, Ion Exchange Membranes, 1st ed., Royal Society of Chemistry, 2004.
- [18] S. Loeb, Large-scale power production by pressure-retarded osmosis, using river water and sea water passing through spiral modules, Desalination 143 (2) (2002) 115–122.
- [19] S. Loeb, Energy production at the dead sea by pressure-retarded osmosis: challenge or chimera? Desalination 120 (3) (1998) 247–262.
- [20] S. Loeb, F. Vanhessen, D. Shahaf, Production of energy from concentrated brines by pressure-retarded osmosis. 2. Experimental results and projected energy costs, J. Membr. Sci. 1 (3) (1976) 249–269.
- [21] W. Ludwig, A. Seppala, M.J. Lampinen, Experimental study of the osmotic behaviour of reverse osmosis membranes for different NaCl solutions and hydrostatic pressure differences, Exp. Thermal Fluid Sci. 26 (8) (2002) 963–969.
- [22] H.A. Massaldi, C.H. Borzi, Nonideal phenomena in osmotic flow through selective membranes, J. Membr. Sci. 12 (1) (1982) 87–99.
- [23] S.K. Ratkje, T. Holt, L. Fiksdal, Effect of biofilm formation on salinity power plant output on laboratory scale, in Industrial membrane processes, AIChE, 1986.
- [24] B. Pilat, Practice of water desalination by electro dialysis, Desalination 139 (1–3) (2001) 385–392.
- [25] B. Van der Bruggen, C. Vandecasteele, Distillation vs. membrane filtration: overview of process evolutions in seawater desalination, Desalination 143 (3) (2002) 207–218.
- [26] S. Loeb, G.D. Mehta, 2-coefficient water transport-equation for pressure-retarded osmosis, J. Membr. Sci. 4 (3) (1979) 351–362.
- [27] R. Audinos, Electric-power produced from 2 solutions of unequal salinity by reverse electro dialysis, Indian J. Chem. Sect. A-Inorg. Bio-Inorg. Phys. Theor. Anal. Chem. 31 (6) (1992) 348–354.